

# EES216: Circuit Analysis

## Midterm Mock Exam

curated by The Peanuts

Name.....ID.....Section.....Seat No.....

**Conditions:** Semi-Closed Book

**Directions:**

1. This exam has 15 pages (including this page).
2. Calculators are permitted (You may bring 100 of them. Haha)
3. Write your name clearly at the top of each page.
4. Reading the problem is optional but highly recommended.
5. You may bring one A3 sheet of note, which will magically become illegible the moment the exam begins.
6. Tears shed on your answer sheet may cause short circuits. Please cry responsibly.

*For solution, click here.*

# Problem 1

Find the equivalent resistance  $R_{ab}$  in the circuit.

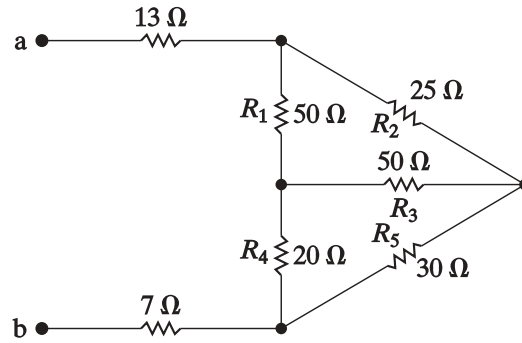

## Problem 2

For an ideal operational amplifier (op-amp), state the values of the following characteristics and briefly explain their significance:

1. Open-loop voltage gain ( $A$ )
2. Input resistance ( $R_i$ )
3. Output resistance ( $R_o$ )

### Problem 3

Let  $a$  be the number of branches in the circuit,  $b$  be the number of nodes, and  $c$  be the number of meshes. Then, compute the value of:

$$a^2 + b^2 - c$$

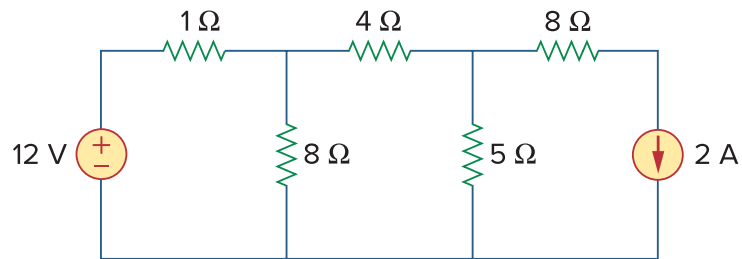

## Problem 4

Take the last digit of your student ID and compute:

$$(\text{last digit}) \bmod 3$$

Based on the result:

- If the result is 0, find a limitation of **Mesh Analysis**.
- If the result is 1, find a limitation of **Node Analysis**.
- If the result is 2, find a limitation of **Superposition Theorem**.

## Problem 5

Determine the value of  $C_T$  in the circuit

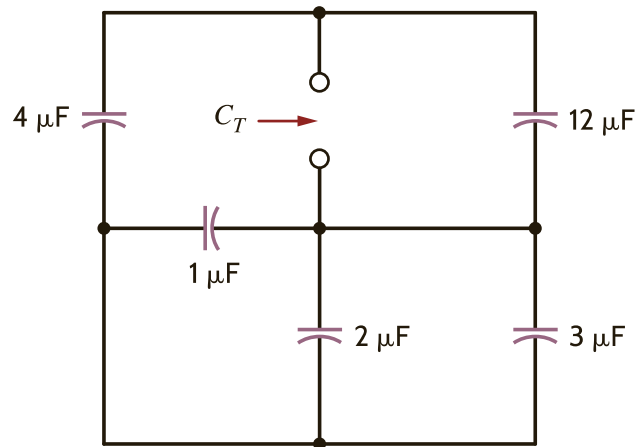

Find the total inductance  $L_T$  in the circuit, All inductors are in millihenrys.

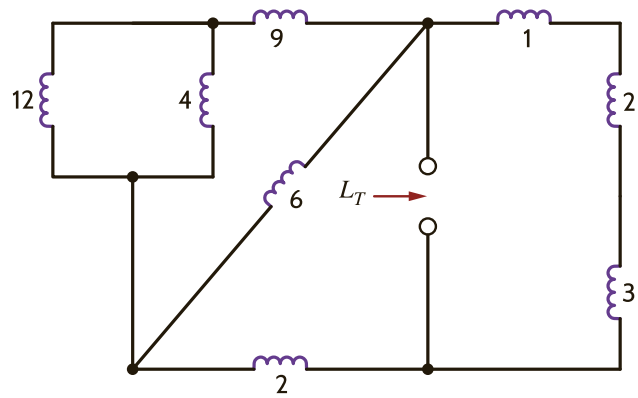

## Problem 6

The current waveform in a 40-mH inductor is shown below. Derive the waveform for the inductor voltage.

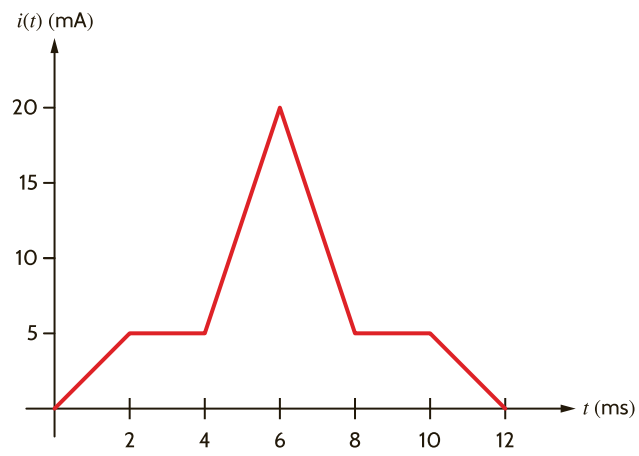

## Problem 7

Given the circuit, find the power dissipated in the  $3\text{-}\Omega$  resistor and the energy stored in the capacitor.

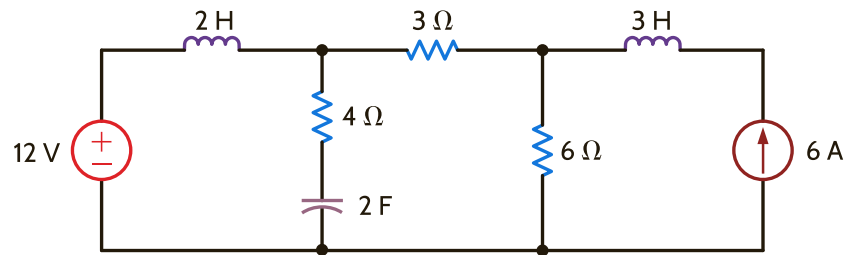



## Problem 8

Find  $V_o$  in the circuit.

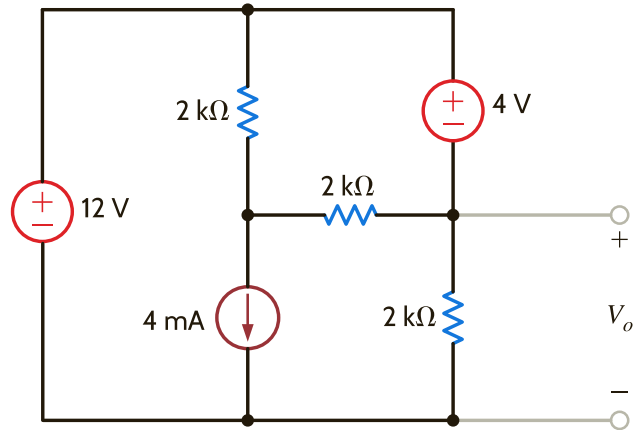

## Problem 9

Determine the loop currents  $I_1, I_2, I_3, I_4$  in the given electrical circuit and express the solution in matrix form.

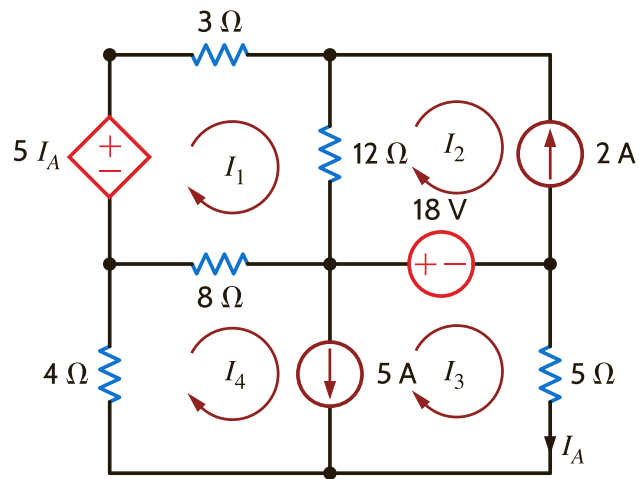

$$\begin{bmatrix} \text{---} & \text{---} & \text{---} & \text{---} \\ \text{---} & \text{---} & \text{---} & \text{---} \\ \text{---} & \text{---} & \text{---} & \text{---} \\ \text{---} & \text{---} & \text{---} & \text{---} \end{bmatrix} \begin{bmatrix} I_1 \\ I_2 \\ I_3 \\ I_4 \end{bmatrix} = \begin{bmatrix} \text{---} \\ \text{---} \\ \text{---} \\ \text{---} \end{bmatrix}$$

## Problem 10

Obtain the Thevenin equivalent circuit at terminal.

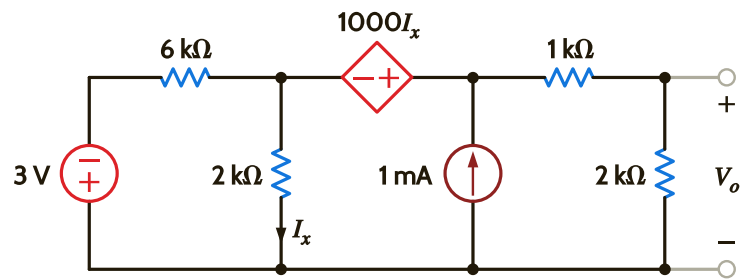

Find  $V_o$  in the circuit.

Find Norton equivalent circuit.

## Problem 11

Find  $R_L$  for maximum power transfer and the maximum power that can be transferred to the load.

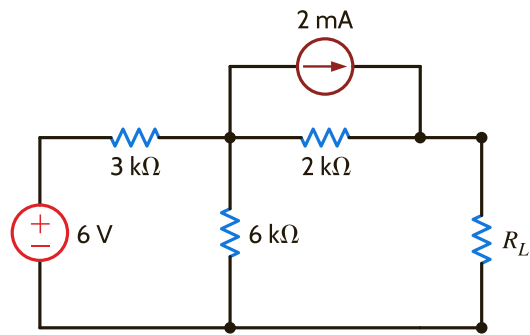

## Problem 12

Given the summing amplifier shown below, find the values of  $R_2$  that will produce an output voltage of  $-3$  V.

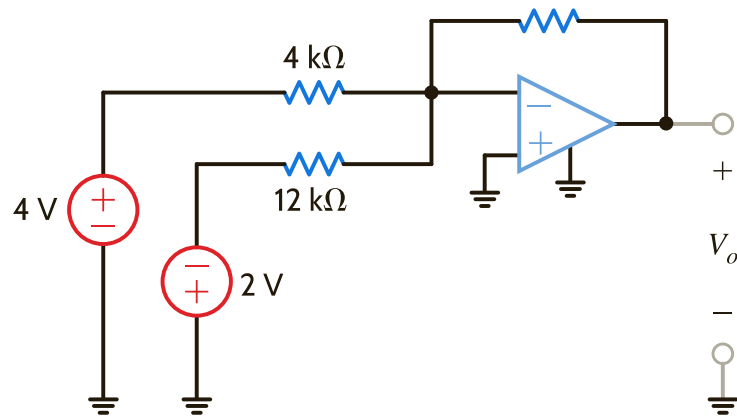

## Problem 13

Consider the circuit. The switch opens at  $t = 0$ . Find  $v_o(t)$  for  $t > 0$ .

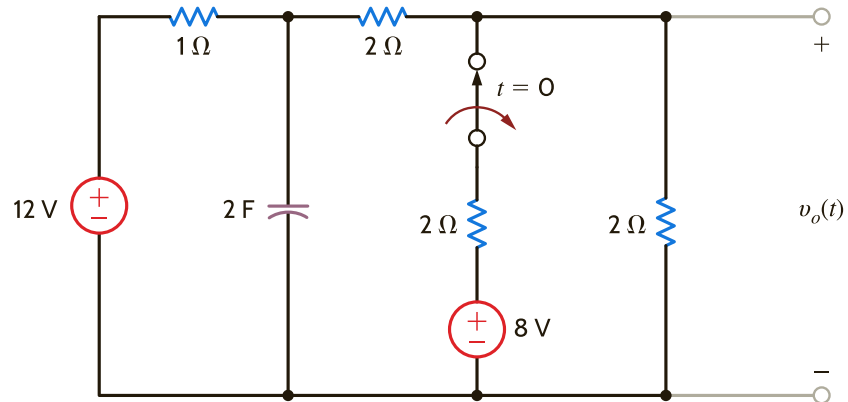

Assume that the circuit reaches steady state after a duration equal to five times the time constant. **Calculate the exact time at which the circuit reaches steady state.**

## Problem 14

The switch in the circuit shown below has been in position a for a long time. At  $t = 0$ , the switch moves instantaneously to position b.

- Find the numerical expression for  $i_o(t)$  when  $t \geq 0$ .
- Find the numerical expression for  $v_o(t)$  when  $t \geq 0^+$ .

